

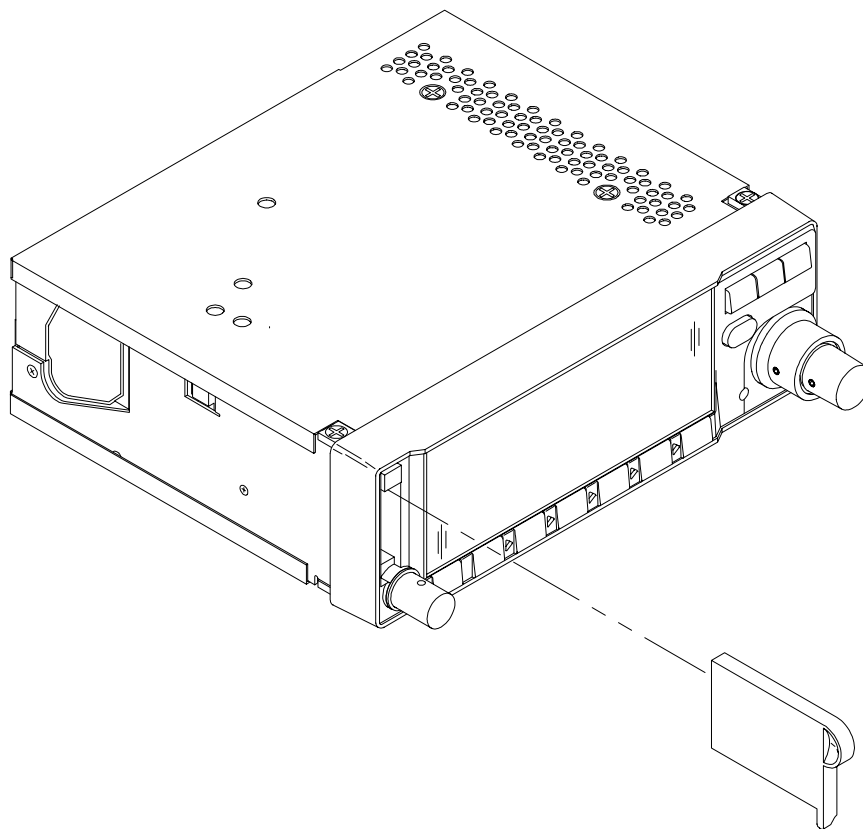

# GARMIN®

## GNC 250/GNC 250XL/GPS 150XL INSTALLATION MANUAL



GARMIN INTERNATIONAL, INC.  
1200 E. 151st STREET  
OLATHE, KANSAS 66062-3426

PART NUMBER: 190-00067-62  
REVISION E, 3 APRIL 1998

© Copyright 1996-1998  
Garmin Corporation  
All Rights Reserved

This publication is the proprietary property of Garmin International Inc. It may not be reproduced or transmitted in any form whether printed or electronic, without the expressed written consent of Garmin International.

Garmin International, Inc.  
1200 E. 151st Street  
Olathe, KS 66062  
U.S.A.

REVISION RECORD				
ECO #	Rev.	Date of Rev.	Description	FAA Approval
Initial	Rev. A,	16 Dec 1996	Initial release	
6811	Rev. B,	07 Mar 1997	Enhance Cooling Air Section	
7708	Rev. C,	10 Dec 1997	Add ant note & STC; Chg btry GPN	
8322	Rev. D,	28 Jan 1998	Chg to/from voltage, install dwg	
8452	Rev. E,	3 April 1998	Corr to btry pk s/n & misc chgs	

# TABLE OF CONTENTS

<b>SECTION 1</b>	<b>GENERAL DESCRIPTION</b>
1.1	INTRODUCTION
1.2	TECHNICAL CHARACTERISTICS
1.2.1	PHYSICAL CHARACTERISTICS
1.2.2	OPERATIONAL CHARACTERISTICS
1.2.3	INTERFACES
1.3	LICENCE REQUIREMENTS
<b>SECTION 2</b>	<b>INSTALLATION CONSIDERATIONS</b>
2.1	ANTENNA CONSIDERATIONS
2.1.1	GPS ANTENNA LOCATION
2.1.2	COMM ANTENNA LOCATION (GNC 250/GNC 250XL only)
2.1.3	ELECTRICAL BONDING
2.1.4	ANTENNA LIMITATIONS
2.1.5	VHF COMM INTERFERENCE OF GPS
2.1.6	COMM ANTENNA INSTALLATION CONSIDERATIONS
2.2	RACK CONSIDERATIONS
2.2.1	ACCESSIBILITY
2.3	CABLING AND WIRING
2.4	COOLING AIR
2.5	ANNUNCIATORS
2.6	EXTERNAL ALTITUDE INPUT
<b>SECTION 3</b>	<b>INSTALLATION PROCEDURE</b>
3.1	INSTALLATION ACCESSORIES
3.2	ANTENNA INSTALLATION
3.3	CABLE INSTALLATION
3.4	RACK INSTALLATION
3.5	UNIT INSTALLATION AND REMOVAL
3.6	COMM ANTENNA INSTALLATION CHECK (GNC 250/GNC 250XL only)
3.7	PLACARD
<b>SECTION 4</b>	<b>POST INSTALLATION CONFIGURATION &amp; CHECKOUT PROCEDURE</b>
<b>SECTION 5</b>	<b>CERTIFICATION</b>
<b>SECTION 6</b>	<b>CONTINUED AIRWORTHINESS</b>
<b>APPENDIX A</b>	<b>CERTIFICATION DOCUMENTS</b>
<b>APPENDIX B</b>	<b>CONNECTOR CHANGES</b>
<b>APPENDIX C</b>	<b>STC PERMISSION</b>

## LIST OF ILLUSTRATIONS

### FIGURE

1-1	PINOUT DEFINITION, 37 PIN DSUB
1-2	PINOUT DEFINITION, 26 PIN HD-DSUB (GNC 250/GNC 250XL only)
1-3	INTERCONNECT SCHEMATIC
1-4	INTERCONNECT SCHEMATIC NOTES
2-1	GPS ANTENNA INSTALLATION CONSIDERATIONS
2-2	UNIT INSTALLATION CONSIDERATIONS
3-1	STUD MOUNT GA 56 INSTALLATION
3-2	FLANGE MOUNT GA 56 INSTALLATION
3-3	COAX CABLE INSTALLATION
3-4	AVIATION RACK DIMENSIONS
3-5	AVIATION RACK INSTALLATION

# SECTION 1 GENERAL DESCRIPTION

## 1.1 INTRODUCTION

This manual describes the physical, mechanical, and electrical characteristics and the installation requirements for the GNC 250, GNC 250XL and GPS 150XL Aviation Kits.

Unless stated otherwise, information found in this manual is applicable to the GNC 250, GNC 250XL and GPS 150XL.

In this manual "UNIT" refers to any of the above units.

## 1.2 TECHNICAL CHARACTERISTICS

All UNITS offer the versatility of fixed installation in a panel mounted aviation rack as well as complete portability.

For TSO Compliance, see Appendix A.

The conditions and tests required for TSO approval of this article are minimum performance standards. It is the responsibility of those desiring to install this article on or within a specific type or class of aircraft to determine that the aircraft operating conditions are within the TSO standards. The article may be installed only if further evaluation by the user/installer documents an acceptable installation and is approved by the Administrator.

### 1.2.1 PHYSICAL CHARACTERISTICS

Width:	6.25 inches
Height:	2 inches
Depth:	5.65 inches
Unit Weight: (See Figure 3-4)	
GA 56 Antenna Weight:	4 oz.
Aviation Rack Weight:	10 oz.
Max Air Speed:	Subsonic
(Structural rating for antenna)	

### 1.2.2 OPERATIONAL CHARACTERISTICS

Operating Temperature Range:	-20 °C to +55 °C
Humidity:	95% non-condensing
Altitude Range:	-1,500 to 50,000 ft.
Voltage Range: (GNC 250/GNC 250XL)	10 to 15.1V DC
Voltage Range: (GPS 150XL)	10 to 33V DC
Power Requirements:(GNC 250/GNC 250XL)	1.35A @ 13.8v (not transmitting)
	5.5A @ 13.8V (transmitting)
Power Requirements: (GPS 150XL)	0.95A @ 13.8V

### 1.2.3 INTERFACES

The UNIT provides interfaces to various general aviation instruments. Figure 1-1 defines the function of each pin on the 37 pin DSUB connector located at the back of the rack. Figure 1-2 defines the function of each pin in the 26 pin HD-DSUB connector (J102) located above the 37 pin connector at the back of the rack. Figures 1-3 and 1-4 defines the interconnects between the rack and other instruments. The following interfaces are provided.

#### 1.2.3.1 37 PIN CONNECTOR (J101)

CDI: (Pins 1 and 4)	Capable of driving up to three 1000 ohm parallel loads, +150 millivolts full scale deflection with a maximum output of +300 millivolts.
To/From: (Pins 2 and 4)	Capable of driving up to three 200 ohm parallel loads, +82 millivolts full scale deflection. Units with Mod Status 1: +190 millivolts full scale deflection.
Nav Flag: (Pins 3 and 4)	Capable of driving up to three 1000 ohm parallel loads, 375 millivolts for flag out-of-view, and +40 millivolts for flag in-view.
OBI data: (Pins 7, 8, and 23)	Output providing bearing to waypoint data for a Bendix/King RMI (KI 229 or equivalent).
Message annunciator: (Pin 20)	Output capable of driving negative logic message annunciators by sinking up to 500mA.
RS232 chan 1 output data: (Pin 24)	Output capable of driving devices as listed in Section 4. Conforms to the EIA specification RS-232C.
RS232 chan 2 output data: (Pin 19)	Output capable of driving devices as listed in Section 4. Conforms to the EIA specification RS-232C.
RS232 chan 1 input data: (Pin 17)	Input capable of receiving data from devices listed in Section 4. Conforms to the EIA specification RS-232C.
RS232 chan 2 input data: (Pin 18)	Input capable of receiving data from devices listed in Section 4. Conforms to the EIA specification RS-232C.
Arrival annunciator: (Pin 12)	Output capable of driving negative logic annunciator by sinking up to 500mA.
ARINC 429 Output A & B: (Pins 15 and 16)	Output capable of interfacing with any device that has an input conforming to the GAMA ARINC 429 specification.

NAV Super Flag Output: Output capable of driving positive logic NAV Super  
(Pin 10) Flag by sourcing up to 500mA for flag out of view (NAV valid).

Battery +,-, Charge Enable Connection for GARMIN remote battery accessory.  
(Pins 30, 34, 29)

#### 1.2.3.2 26 PIN CONNECTOR (J102) (GNC 250/GNC 250XL only)

MIC Audio Hi and Lo: Input requiring 275mV RMS into 470 ohm load.  
(Pins 2 and 3) (Standard carbon or dynamic MIC containing transistorized pre-amp.)

MIC Key: Input, when grounded, keys the transmitter.  
(Pin 4)

COMM Audio Hi and Lo: Output capable of driving a 500 ohm load with  
(Pins 5 and 6) 100mW.

MIC Intercomm: Input requiring 125 mV RMS into 470 ohm load.  
(Pin 8) (Standard carbon or dynamic MIC containing transistorized pre-amp.)

Remote Transfer: Input, when grounded, swaps the active and  
(Pin 10) standby COMM frequencies.

TX Interlock: Input, when grounded, reduces receiver sensitivity so  
(Pin 12) squelch will not break when another transceiver is keyed.

Altimeter input: Capable of receiving encoded output data from any  
(Pins 14-24) parallel altimeter device.

Remote Enter: Input, when ground, functions the same as the enter  
(Pin 26) key on the UNIT front panel.

#### 1.2.3.3 COMM Antenna Connector (J4) (GNC 250/GNC 250XL only)

Capable of providing 5 watts, minimum at 13.8V. Sensitivity of 6 dB SNR, minimum, at 2 uV. The COMM antenna shall be approved to TSO C37( ) and C38( ).

### 1.3 LICENCE REQUIREMENTS

If any of these devices are used in home or in office, connected to a personal computer, then the below 4 paragraphs are applicable.

These devices comply with Part 15 of the FCC limits for Class B digital devices. This equipment generates, uses and can radiate radio frequency energy and if not installed and used in accordance with the instructions, may cause harmful

interference to radio communications. However, there is no guarantee that interference will not occur in a particular installation. If this equipment does cause harmful interference to other equipment, which can be determined by turning the equipment off and on, the user is encouraged to try and correct the interference by relocating the equipment or connecting the equipment to a different circuit than the affected equipment. Consult an authorized dealer or other qualified avionics service technician for additional help if these remedies do not correct the problem. These devices comply with Part 15 of the FCC rules. Operation is subject to the following conditions: (1) This device may not cause harmful interference, and (2) this device must accept any interference received, including interference that may cause undesired operation.

These units do not contain any user-serviceable parts. Repairs should only be made by an authorized GARMIN service center. Unauthorized repairs or modifications could void your warranty and your authority to operate this device under Part 15 Regulations.

FCC requires GARMIN to inform users that these units meet the more stringent requirements “For Home or Office Use”.

The following guidance is provided to help ensure the proper licensing of the GNC 250 and GNC 250XL COMM.

- 1) Telecommunications Act of 1996 effective February 8, 1996 provides the FCC discretion to eliminate radio station license requirements for aircraft. At present, and individual license to operate the GNC 250XL and GNC 250 aboard a private aircraft is not needed in many circumstances. Please see FCC Fact Sheet PR5000 or contact the FCC at 800 322-1117 for more information.
- 2) No license change is required for an aircraft which already has a station license per FCC 404 Instructions dated 1994.
- 3) If an aircraft license is required or desired contact the FCC at 800 322-1117 to request FCC form 404, Application for Aircraft Radio Station License to apply for FCC authorization. FCC also has a “Fax on Demand” service to provide forms by fax at 202-418-0177.

## **SECTION 2 INSTALLATION CONSIDERATIONS**

Careful planning and consideration of the suggestions in this section are required to achieve the desired performance and reliability from the UNIT.

### **2.1 ANTENNA CONSIDERATIONS**

#### **2.1.1 GPS ANTENNA LOCATION**

The UNITS GA 56 Antenna must be mounted on top of the aircraft. For best performance select a location with an unobstructed view of the sky above the aircraft when in level flight. Figure 2-1 illustrates a typical GPS antenna installation.



For rotorcraft, locate the GA 56 antenna:

- 1) As far from the main rotor hub as possible. This reduces the percentage of time the blade blocks the antenna.
- 2) As far below the blade surface as possible if installing the antenna under the blade. This reduces signal distortion caused by the blades.

The antenna should be located at least 3 feet from transmitting antennas such as VHF Comm, HF transmitter, DME, Transponder, and Radar.

#### 2.1.2 COMM ANTENNA LOCATION (GNC 250/GNC 250XL only)

The COMM antenna should be well removed from all projections, engines and propellers. The ground plane surface directly below the antenna should be a flat plane over as large an area as possible (18 inches square minimum).

The antenna should be mounted a minimum of 6 feet away from any DME antennas, 4 feet from any ADF sense antennas, and a minimum of 3 feet from the UNITS and its GPS antenna.

The UNITS COMM antenna connector is specified to have installed GPN 330-00067-00 (1.57542 GHz notch filter) to minimize interfering harmonics.

#### 2.1.3 ELECTRICAL BONDING

No special precautions need to be taken to provide a bonding path between the GPS antenna and the aircraft structure.

Follow the manufacturers instructions for the COMM antenna. (GNC 250/GNC 250XL only)

#### 2.1.4 ANTENNA LIMITATIONS

GARMIN'S GA 56 Antennas are recommended for installations where the airspeed of the aircraft will be subsonic.

See the COMM antenna specification for its limitations. (GNC 250/GNC 250XL only)

#### 2.1.5 VHF COMM INTERFERENCE OF GPS

On many panel-mounted aircraft, VHF COMM's can radiate strong harmonics from both the comm itself and its antenna. The GNC 250/GNC 250XL COMM section will not interfere with its GPS section. However, placement of the UNITS GPS antenna relative to all COMM's and COMM antenna, including its own, is critical.

Use the following guidelines, in addition to others in this document, when locating the UNIT and its antennas.

GPS Antenna: Locate as far as possible from all COMM antennas and all COMMs (including the GNC 250/GNC 250XL). The GPS antenna will be much less sensitive to COMM antennas that use a 1.57542 GHz notch filter.

UNIT: Locate as far as possible from all COMM antennas.

If a COMM antenna is found to be the problem, a 1.57542 GHz notch filter (GPN 330-00067-00) may be installed in the VHF COMM coax, as close to the COMM as possible. This filter (GPN 330-00067-00) is required for the GNC 250/GNC 250XL transmitter.

If a COMM is found to be radiating, the following can be done:

- 1) Replace or clean VHF COMM rack connector to assure good coax ground.
- 2) Place a grounding brace between the GNC 250/GNC 250XL/GPS 150XL, VHF COMM, and ground.
- 3) Shield the VHF COMM wiring harness.

#### 2.1.6 COMM ANTENNA INSTALLATION INSTRUCTIONS (GNC 250/GNC 250XL only)

The COMM antenna should be installed according to the manufacturer's recommendations.

### 2.2 RACK CONSIDERATIONS

#### 2.2.1 ACCESSIBILITY

Plan a location which gives the pilot complete and comfortable access to the entire keypad and which is plainly visible from the pilot's perspective. Check that there is adequate depth for the rack in the instrument panel. A location away from heating vents or other sources of heat generation is optimal. Figure 2-2 illustrates a typical aviation rack installation.

### 2.3 CABLING AND WIRING

The recommended antenna cable type for both antennas is M17/155-0001 (RG-58A/U) per MIL-C-17. Maximum allowable length for the GPS antenna using this cable type is 40 feet. Other cable types with 50 ohms nominal impedance and longer lengths can be used for the GPS antenna, provided the installer insures that the attenuation does not exceed 10dB at 1.5 GHz for the specific installation. Check that there is ample space for the cabling and mating connectors. Avoid sharp bends in cabling, particularly the COMM antenna cable (GNC 250/GNC 250XL only), and routing near aircraft control cables.

Cabling for the UNIT should not be routed near components or cabling which are sources of electrical noise.

Do not route the COMM antenna cable near any ADF antenna cables. (GNC 250/GNC 250XL only)

Route the GPS antenna cable as far as possible away from all COMMs and COMM antenna cable.

## 2.4 COOLING AIR

Cooling air is highly recommended for the UNIT, but not required. Cooling is recommended to maximize display performance for the GNC 250XL and GPS 150XL. As with any electronic equipment, reduced operating temperature can contribute to increased reliability. Additionally, location of the UNIT in a stack of other power dissipating equipment can produce unacceptably high ambient air temperatures around the unit. A 5/8 inch diameter air fitting is provided on the rear of the mounting rack for the purpose of admitting cooling air under such conditions.

## 2.5 ANNUNCIATORS

If the installation includes any electrical interface with other flight instruments, an annunciator may be required. Refer to current FAA directives.

## 2.6 EXTERNAL ALTITUDE INPUT

Pressure altitude input from an external source is not required but it may benefit the UNITS system performance during times of minimal satellite coverage or poor satellite geometry. Pressure altitude input from an external source may be derived from a RS-232 compatible serial altitude input or Parallel Greyscale/Gillham Altitude (GNC 250/GNC 250XL only) as described in Section 4 of this manual. Gillham Altitude is not required when serial altitude is used.

# SECTION 3 INSTALLATION PROCEDURE

## 3.1 INSTALLATION ACCESSORIES

The following installation accessories are available:

### ANTENNA AND RACK OPTIONS

010-10040-01	GA 56 ANTENNA KIT, W/O CABLE	
Includes:	011-00134-00 GA56 ANTENNA SUB-ASSEMBLY	1
	115-00031-00 BACKING PLATE	1
	210-10004-09 NUT, SELF-LOCKING, #8-32	4
	253-00002-00 ANTENNA GASKET	1
010-10040-02	GA 56 FLANGE MOUNT ANTENNA	
Includes:	011-00147-00 FLANGE MOUNT GA56 ANTENNA SUB-ASSEMBLY	1
	115-00080-00 NUT PLATE	1
	211-62212-14 SCREW, #10-32 X 5/8	4
	253-00011-00 ANTENNA GASKET	1
320-00003-00	15 FT LOW-LOSS AVIATION ANT. EXTENSION CABLE WITH RIGHT ANGLE BNC CONNECTOR	
320-00003-02	30 FT LOW-LOSS AVIATION ANT. EXTENSION CABLE WITH RIGHT ANGLE BNC CONNECTOR	
330-00087-00	CONNECTOR, BNC, MALE, CLAMP	

Note: One cable assembly and one BNC connector are required to make the antenna cable, or it can be fabricated by the installer from materials meeting the requirements of paragraph 2.3.

011-00154-00 MOUNTING RACK, (WITHOUT CONNECTORS)

Note: A mounting rack is required for approved installations. The following hardware is required for installation of the mounting rack, but is not provided:

#6-32 Flat Head Screw (4 ea.) #6-32 Self-locking Nut (4 ea.)

011-00313-00 CONNECTOR, (J1 and J2) Kit (GNC 250/GNC 250XL)

011-00313-01 CONNECTOR,(J1) Kit (GPS 150XL)

#### DATA BASE OPTIONS

010-10038-00 MEMORY CARD - WORLDWIDE DATABASE

010-10038-01 MEMORY CARD - AMERICAS DATABASE

010-10038-02 MEMORY CARD - INTERNATIONAL DATABASE

010-10032-03 MEMORY CARD - USER

#### MISCELLANEOUS OPTIONS

010-10075-00 PC KIT

190-00067-50 GNC 250 PILOT'S GUIDE

190-00067-51 GNC 250 QUICK REFERENCE GUIDE

190-00067-56 GNC 250 IN MOONEY M20J DOCUMENTED INSTALLATION

190-00067-60 GNC 250XL PILOT'S GUIDE

190-00067-61 GNC 250XL QUICK REFERENCE GUIDE

190-00067-66 GNC 250XL IN MOONEY M20J DOCUMENTED INSTALLATION

190-00067-80 GPS 150XL PILOT'S GUIDE

190-00067-81 GPS 150XL QUICK REFERENCE GUIDE

190-00067-86 GPS 150XL IN MOONEY M20J DOCUMENTED INSTALLATION

330-00067-00 GPS 1.57542 GHZ NOTCH FILTER

362-00014-00 WALL ADAPTER - 110 VAC

010-10057-00 28 TO 14V CONVERTER (GNC 250/GNC 250XL ONLY) (Consists of 011-00181-00)

010-10074-00 REMOTE BATTERY PACK (Consists of 011-00182-00)

THE FOLLOWING INSTALLATION ACCESSORIES ARE REQUIRED BUT NOT PROVIDED: (GNC 250/GNC 250XL ONLY)

COMM ANTENNA: BROAD BAND 50 OHM VERTICALLY POLARIZED WITH COAXIAL CABLE.

HEADPHONES: 500 OHM NOMINAL IMPEDANCE

MICROPHONE LOW IMPEDANCE CARBON OR DYNAMIC WITH TRANSISTORIZED PRE-AMP.

## 3.2 ANTENNA INSTALLATION

For the COMM antenna, follow the manufacturers instructions. (GNC 250/GNC 250XL only)

The remainder of this section applies to the GPS antenna. The GA 56 Antenna outline and footprint dimensions are shown in Figures 3-1 and 3-2.

- A. Using the backing plate as a template, mark the location of the mounting holes and the through hole for coax cable. Drill or punch the holes.
- B. The antenna installation must provide adequate support for the antenna considering a maximum drag load of 5 lbs. for the GA 56 antennas (at subsonic speed). Install a doubler plate to reinforce thin skinned aircraft. Observe guidelines for acceptable installation practices as outlined in AC 43.13-2A.
- C. Seal the antenna and gasket to the fuselage using a good quality electrical grade sealant. Use caution to insure that the antenna connector is not contaminated with sealant. Insure that the mounting screws are fully tightened and that the antenna base is well seated against the gasket. CAUTION: Do not use construction grade RTV sealant or sealants containing acetic acid. These sealants may damage the electrical connections to the antenna. Use of these type sealants may void the antenna warranty.

### 3.3 CABLE INSTALLATION

- A. Route the coax cable to the rack location keeping in mind the recommendations of Section 2. Secure the cable in accordance with good aviation practice.
- B. Trim the coaxial cable to the desired length and install the BNC connector (330-00087-00) per the cabling instructions on Figure 3-3. If the connector is provided by the installer, follow the connector manufacturer's instructions for cable preparation.
- C. Contacts for the 37 and 26 pin connectors must be crimped into the individual wires of the aircraft wiring harness. The following table lists contact part numbers (for reference) and crimp tools:

Contacts					
	Standard Density Connectors				Hi Dens. Connector
	37 socket connector (J1 on unit)		9 pin connector (on battery pack)		26 pin connector (J2 on unit)
	20-24 AWG socket contact	18 AWG socket contact	20-24 AWG pin contact	18 AWG pin contact	22-28 AWG pin contact
Garmin p/n	336-00022-00	336-00023-00	336-00024-00	336-00025-00	336-00021-00
military p/n	M39029/63-368	n/a	M39029/64-369	n/a	M39029/58-360
Amp	205090-1	n/a	205089-1	n/a	204370-2
Positronic	M39029/63-368	FC6018D	M39029/64-369	MC6018D	M39029/58-360
ITT Cannon	031-1007-042	see note	330-5291-037	see note	030-2042-000

Tools							
	Hand Crimping Tool	Standard Density Connectors (size 20 contacts)				Hi Dens. Connector (size 22D)	
		pin or socket contacts (20-24 AWG)		pin or socket contacts (18 AWG)		pin contacts (22-28 AWG)	
		positioner	insert/extract	positioner	insert/extract	positioner	insert/extract
military p/n	M22520/2-01	M22520/2-08	M81969/1-02	n/a	M81969/1-02	M22520/2-09	M81969/1-04
Positronic	9507	9502-5	M81969/1-02	9502-11	M81969/1-02	9502-3	M81969/1-04
ITT Cannon	995-0001-584	995-0001-604	980-2000-426*	see note	274-7048-000*	995-0001-739	n/a
Amp	601966-1	601966-5	91067-2	n/a	n/a	601966-6	91067-1
Daniels	AFM8	K13-1	M24308/1-02	K774	M24308/1-02	K42	M24308/18-1
Astro	615717	615725	M81969/1-02	see note	M81969/1-02	615724	M81969/1-04

\* Insert/extract tools from ITT Cannon are all plastic, others are plastic with metal tip.

Non- GARMIN part numbers shown are not maintained by GARMIN and consequently are subject to change without notice.

NOTE: Alternate contacts for 18 AWG wire: As an alternate to the Positronic contacts listed (and provided in the install kit), the installer may use pin contacts made by ITT Cannon as follows: Socket contact - ITT Cannon p/n: 031-10007-001, Pin contact - ITT Cannon p/n: 330-5291-055. These contacts require the use of a different crimp tool positioner than that shown in the table, with part numbers as follows: Daniels p/n: K250, Astro p/n: 616245, or ITT Cannon p/n: 980-00005-722.

See Appendix B for information regarding obsolete stamped type contacts.

### 3.4 RACK INSTALLATION

- A. Figure 3-4 shows outline dimensions for the aviation rack. Install the rack in a rectangular 6.320" x 2.000" hole in the instrument panel. Exercise caution when installing the rack into the instrument panel. The rack is designed to facilitate removal of the UNIT for portable use. Deformation of the rack may make it difficult to install and remove the UNIT.
- B. Install the rack in the aircraft panel using four #6-32 countersunk screws and four self-locking nuts or other FAA approved methods as per Advisory Circular 43.13-1A. The screws are inserted from the inside through the holes in the sides of the rack (see Figure 3-5).

### 3.5 UNIT INSTALLATION AND REMOVAL

The UNIT is installed in the rack by gently sliding it straight in until it rests against the back of the rack. A 3/32 inch hex drive tool is then inserted into the access hole at the bottom of the unit face. Rotate the hex tool clockwise while pressing on the left side of the Bezel until the unit is firmly seated in the rack.

To remove the unit from the rack, insert the hex drive tool into the access hole on the unit face and rotate counter-clockwise until the mounting screw turns freely and the unit protrudes about 3/8 inch from the panel.

Be sure not to over tighten the unit into the rack. The application of hex drive tool torque exceeding 15 in\*lbs can damage the locking mechanism.

### 3.6 COMM ANTENNA INSTALLATION CHECK (GNC 250/GNC 250XL only)

Check for insertion loss and VSWR. VSWR should be checked with an in-line type wattmeter inserted in the coaxial transmission line between the transceiver and the antenna. Any problem with the antenna installation will most likely be seen as a high reflected power. A VSWR of 3:1 will result in a 25% loss in power.

### 3.7 PLACARD

After completing the installation, a placard stating that the UNIT is limited to VFR use must be installed on the panel in clear view of the pilot. The placard may be Garmin p/n 161-00024-00 as supplied with the unit, or a suitable equivalent.

## **SECTION 4 POST INSTALLATION CONFIGURATION & CHECK-OUT PROCEDURE**

Before starting the below operations, unit initialization must occur. Do this by first removing any data cards and then turning the unit on. Press enter in response to "Select operating mode Normal ok?". Press enter in response to "No Jeppesen database rte/prx limited to user wpts ok?". After the satellite status page is displayed for 5 seconds the unit may be turned off. Proceed with the following steps.

## 4.1 TEST MODE OPERATIONS

With power applied to the aviation rack and the UNIT unit off, depress and hold the ENT key and turn the unit on (release the ENT key when the display activates). The first page displayed is the Display Test Page. While in TEST MODE, test pages can be selected by ensuring the flashing cursor is off and rotating the outer knob either direction. To change data on the displayed test page, depress the CRSR key and the cursor will highlight the standby COMM frequency for the GNC 250/GNC 250XL and the configuration selection for the GPS 150XL. In the GNC 250/GNC 250XL, press cursor again to move to the configuration selections. The inner knob will change the data on the selected field. The ENT key or the outer knob will advance to the next field on the page. Pressing the CRSR key again will stop the current field from flashing, allowing the outer knob to select the next test page. The ENT key is used to enter a new value into the OBI data field after selecting the desired value using the inner and outer knobs (see the appropriate chapter of the Pilot's Guide for more information on page and data selection).

Note that some pages found in test mode are intended for bench testing and are not discussed here.

## 4.2 INSTALLATION CONFIGURATION

Note that the below pages are in the order found when rotating the outer knob clock-wise starting at the Display Test page. See Section 4.1 to get to this page.

### 4.2.1 DISPLAY ADJUSTMENT

This page is called Display Intensity in the GNC 250 and called Lighting in the GNC 250XL and GPS 150XL.

This page allows the setting of parameters that, in the automatic mode, affect the GNC 250 display and lighting brightness and the GNC 250XL/GPS 150XL display backlight and lighting brightness.

“response time” sets the speed with which the brightness responds to ambient light changes. The higher the number the slower the display responds.

“min” sets the minimum brightness of the display. The higher the number the brighter the minimum brightness.

“slope” sets the sensitivity the brightness of the display has to changes in ambient light. The higher the number the brighter the display will be for a given increase in ambient lighting.

For more information on the GNC 250 display setting, see the Display Intensity Page described in the Pilot's Guide (GPN 190-00067-50).

For more information on the GNC 250XL and GPS 150XL display setting see the Display Contrast and Mode Set page and the Backlight Set page described in its Pilot's Guide (GNC 250XL: 190-00067-60 and GPS 150XL: 190-00067-80)

#### 4.2.2 I/O CHANNEL 1

Select the I/O CHANNEL 1 Test Page. Change the selectable input and output to match that of the installed equipment. The available options are:

Input:	<u>Field</u>	<u>Description</u>
	off	No units connected to Channel 1 input
	icarus-alt	Serial altitude received from: Icarus, Model 3000, Mode C Serializer
	shadin-alt	Serial altitude received from: Shadin 9000T Serializer System (Non-TSO'd) Shadin 9200T Series Serializer System (Non-TSO'd) Shadin 8800T Series Encoder System (TSO'd)
	shadin-fuel	Fuel information received from: Shadin 91204XT Series Digital Fuel Management System (TSO'd) Shadin 91053XT Series Digital Fuel Management System (TSO'd)
	arnav/ei-fuel	Fuel information received from: Arnav, Model FC-10, Fuel Computer (TSO'd) Arnav, Model FT-10, Fuel Totalizer (TSO'd) Electronics International, Model FP-5L, Fuel Flow Computer (Non-TSO'd)
	shadin-adc	Air data information received from: Various models from the 9628XX-X family
	shadin-fadc	Fuel/Air data information received from: Various models from the 9628XX-X family

Note: Verify with manufacturer of data input device that unit supports GARMIN interface.

Output:	<u>Field</u>	<u>Description</u>
	off	No units connected to Channel 1 output
	aviation	Serial position, velocity and navigation data to: Argus, Model 3000, Moving Map Argus, Model 5000, Moving Map Argus, Model 7000, Moving Map Stormscope, Series II with Navaid, Moving Map Shadin, 91204X[T] Digital Fuel Management System (TSO'd) Shadin, 91053X[T] Digital Fuel Management System Electronics International, Model FP-5L, Fuel Flow Computer (Non-TSO'd) Shadin, Model 9628XX-X Fuel/Airdata Computer (TSO'd) GARMIN, GPS 195 GARMIN, GPS III



### 4.2.3 ARINC 429 CHANNEL

Select the ARINC 429 Channel Test Page. Change the selectable output to match that of the installed equipment. The available options are:

Input: No selection available

Output:	<u>Field</u>	<u>Description</u>
	off	No units connected to ARINC 429 output
	Collins PL2 EFS	Collins Pro Line 2 EFIS connected (w/ GAMA)
	King EFS 40/50	King Radio EFIS 40 or 50 connected (w/ GAMA)
	w/o GAMA labels	Any unit that receives standard 429 output

Below is a list of labels output by the UNIT:

#### **Navigation/position data**

<u>Label</u> <u>(octal)</u>	<u>Description</u>
100	Selected course
114	Desired track
115	Bearing to waypoint
116	Cross track error
121	Horizontal command (to autopilot)
251	Distance to go
252	Time to go
310	Present position latitude
311	Present position longitude
312	Ground speed
313	Ground track
147*	Magnetic variation
261*	GPS navigation mode
275*	Navigation status
326*	Lateral scale factor
351*	Distance to destination
352*	Time to destination

#### **Flight plan data**

<u>Label</u> <u>(octal)</u>	<u>Description</u>
074*	Flight plan header
075*	Active from/to waypoints
113*	Message checksum
300*	Station magnetic variation/type/class
303*	Message length/type/number

- 304\*      Waypoint identifier characters 1-3
- 305\*      Waypoint identifier characters 4-6
- 306\*      Waypoint latitude
- 307\*      Waypoint longitude

**Identification data**

Label  
(octal)      Description

- 377      Equipment identifier
- 371\*      General Aviation equipment identifier

\*These labels are formatted per the General Aviation Manufacturers Association (GAMA) definition. Note that the use of a 429 device w/o GAMA will cause the loss of the above asterisked labels.

4.2.4 CDI CALIBRATION

Select the test page displaying CDI output calibration. Place the cursor on the alignment field by using the outer knob. Use the inner knob to adjust the CDI needle until it is centered. Once centered, turn the cursor off to complete the calibration process.

4.2.5 CONFIGURATION

Select the Configuration Test Page. Change the selectable Strap and Fuel selections to match that of the aircraft. The available options are:

- Fuel:      av gas              Using Aviation gas (5.8 lbs/gal)
- jet A                Using Jet A/Jet A-1 fuel (6.7 lbs/gal)
- jet B                Using Jet B (JP-4) fuel (6.5 lbs/gal)

NOTE: The Fuel option is used to designate the type of fuel used so that the correct fuel density will be used in calculations.

- Remote Battery:      none
- installed

NOTE: If installed is selected when a battery is not installed erroneous voltages will be shown on the Power Test page and invalid battery messages will be issued in normal operating modes.

4.2.6 I/O CHANNEL 2

NOTE: This page is not found in the Test Pages but is included here to aid installation. For more information see SET Pages in the Pilot's Guide (GPN 190-00067-50).

Select the I/O CHANNEL 2 Set Page. Change the selectable input and output to match that of the installed equipment. The available options are:

Input:	<u>Field</u>	<u>Description</u>
	off	
	rtcm 104	RTCM SC-104 Compatible Differential GPS receiver.

NOTE: Below is a list of the RTCM SC-104 messages that the unit will receive.

- Message type 1 - Differential GPS correction
- Message type 2 - Delta differential GPS corrections
- Message type 3 - Reference station parameters
- Message type 9 - High rate differential GPS corrections

Output:	Field	Description
	off	No units connected to Channel 2 output.
	plotting	Serial position, velocity, navigation and satellite data to: NMEA 0183 Version 2.0 compatible mapping device or GARMIN PC software.

NOTE: Below is a list of the NMEA 0183 sentences (with maximum number of characters) that the GNC 250 transmits.

- RMC -70 characters
- GGA -72 characters
- GSA -57 characters
- GSV -140 characters (70 characters x 2 sentences)
- RMB -70 characters
- BOD -35 characters
- WPL -38 characters
- \*PGRME -35 characters
- \*GARMIN proprietary accuracy error sentence that is not a part of the NMEA 0183 standard.

### 4.3 GROUND TEST

The UNIT ground test procedure incorporates a series of display pages to test CDI/flag, OBI, annunciators, external switches, altitude inputs, and power functions of the unit.

Note that the below pages are in the order found when rotating the outer knob counter-clockwise starting at the Display Test page. See Section 4.1 to get to this page.

#### 4.3.1 POWERTEST

Select the Power Test page. This page reports the status of the UNIT external power source, remote battery and internal memory battery. In the below “voltage” represents the voltage currently measured for that function.

The first line of power information shows the source of external power as shown below:

External Power “voltage”  
Battery Power  
Wall Adapter

The presence of a Wall Adapter will override the other two sources. Battery Power will not be shown unless on the Configuration Page the Remote Battery is selected as Installed. The higher voltage of External Power or Battery Power will determine which is shown.

The next line shows the status of the Remote Battery as shown below:

Rmt Pak none (If on the Configuration page Remote Battery is selected as none)

Rmt Pak “voltage” “mode” “auto status” “mode” represents the mode of the charger enable to the remote battery pack and is selectable. “On” enables the charger. “Off” disables the charger. “Auto” enables the charger if the External Power is the current source and its voltage is high enough. When in “Auto” mode “auto status” will be either “on” or “off” reflecting whether the charger is enabled or disabled.

The next line reports the status of the internal memory battery as shown below:

Mem Batt ok/low.

Note that the “TX” field will light on the display but the transmitter will not actually transmit when the UNIT is powered from the wall charger.

#### 4.3.2 CDI AND FLAG TEST

Select the the CDI Test Page. Using the controls on the UNIT front panel, make the selections indicated below and verify the interfaces as appropriate:

##### CDI

Full scale left	Ensure the CDI is deflected full scale left (5 dots)
Full scale right	Ensure the CDI is deflected full scale right (5 dots)
Centered	Ensure the CDI is centered

##### TO/FROM/FLAG

TO	Ensure TO flag is visible
FROM	Ensure FROM flag is visible
FLAG	Ensure TO and FROM are NOT visible

##### CDI FLAG

IN VIEW	Ensure CDI flag is in view
OUT OF VIEW	Ensure CDI flag is out of view

## SUPERFLAG

IN VIEW

Ensure superflag in view

OUT OF VIEW

Ensure superflag out of view

### 4.3.3 ANNUNCIATOR TEST

Select the Annunciator Test Page. Using the controls on the UNIT front panel make the selections indicated below and verify the interfaces as appropriate:

#### MSG Annunciator

OFF

Ensure the Message Annunciator is OFF

ON

Ensure the Message Annunciator is ON

#### Arrival Annunciator

OFF

Ensure the Arrival Annunciator is OFF

ON

Ensure the Arrival Annunciator is ON

### 4.3.4 EXTERNAL SWITCH TEST (GNC 250/GNC 250XL only)

Select the External COM Switches Page. For each of the following installed remote switches perform the following:

Press Remote Enter and verify the Rmt ent field changes from off to on.

Press PTT and verify the PTT field changes from off to on.

Press Remote Transfer and verify the Rmt xfr field changes from off to on.

### 4.3.5 COMMUNICATIONS LOOPBACK TEST

This page displays the results of communication loop back tests. Three channels are tested: RS232 channels 1 and 2 and Arinc 429. Results of the test are either "OPEN" or "OK". Open means the channel's transmitter and receiver are not connected or the test failed. The tests are performed continuously while on this page except for RS232 channel 2. This channel is only tested at power on and the results displayed on this page. Therefore the unit must be turned off and the receiver/transmitter connected or disconnected and then turn the unit on to perform the test. The 429 channel may be connected to loop back to test the 429 transmitter.

To test the channels:

RS232 channel 1: Connect RS232 channel 1 receiver and transmitter

RS232 channel 2: Connect RS232 channel 2 receiver and transmitter

A429 : Connect Arinc 429 transmitter and receiver

#### 4.3.6 ALTITUDE INPUT TEST (GNC 250/GNC 250XL only)

Select the Gray Code Altitude Test Page if this input is used. Verify that the altitude input is reading the correct altitude. NOTE: This does not display serial altitude.

#### 4.3.7 OBI TEST

Select the OBI Test Page. Using the controls on the UNIT front panel, make the selections indicated below and verify the interfaces as appropriate:

##### OBI Data

VALID	Ensure that the OBI indicates the proper value
INVALID	Ensure the OBI is invalid

OBI Value	Ensure that the OBI displays the value entered when the VALID option is selected
-----------	--

NOTE: The 3 lines that make up the OBI interface may be toggled individually. This may be done from the “Value” field. Cycle this field to the desired line (either CLOCK, DATA or SYNC) and toggle the output to HIGH or LOW.

#### 4.3.8 SIGNAL ACQUISITION TEST

The Self Test Page will be displayed followed by the Data Base Page. Upon approval of the Data Base Page, the Satellite Status Page will be displayed. If unable to acquire satellites, relocate the aircraft away from obstructions which might be shading reception. If the situation does not improve, check the antenna installation.

Once GPS position information is available, use the DIRECT-TO key to activate the navigation function to a nearby NAVAID, intersection, or airport. Ensure any connected equipment is transmitting data to and/or is receiving data from the UNIT and is functioning properly (see the Pilot's Guide for more information on the DIRECT-TO function).

#### 4.3.9 OPTIONAL VHF COMM INTERFERENCE EVALUATION

The below evaluation is included for installation information only. It can be used as a means to gauge VHF COMM interference and, in conjunction with Section 2.1.5, be used to improve an installation. Passing the below evaluation is not required.

- a) Go to the Satellite Status Page, verify that 7 to 8 satellites have been
- b) See that the “NAV” flag is out of view
- c) Select 121.15 MHZ on COMM1

- d) Transmit for a period of 20 seconds
- e) Verify that the flag does not come into view
- f) Repeat steps d) and e) for the following frequencies:  
121.175, 121.20, 131.250, 131.275 and 131.300
- g) Repeat steps c-f for all COMMs installed in the aircraft
- h) If the "NAV" flag comes into view, refer to Section 2.1.5 for options to improve performance.

#### 4.3.10 VHF COMM CHECK (GNC 250/GNC 250XL only)

A flight test is recommended after the installation is completed to insure satisfactory performance. To check the communications transceiver, maintain an appropriate altitude and contact a ground station facility at a range of at least 50 nautical miles. Contact a ground station close in. Press the squelch disable button to defeat the automatic squelch feature and listen for any unusual electrical noise which would reduce the COMM receiver sensitivity by increasing the squelch threshold. If possible, verify the communications capability on both the high and low end of the VHF COMM band.

## **SECTION 5 CERTIFICATION**

The GNC 250/GNC 250XL/GPS150XL is certified to the airworthiness criteria in Advisory Circular 20-138 for VFR use in the en route and terminal phases of flight.

The GNC 250/GNC 250XL/GPS 150XL initial certification was accomplished via a STC by GARMIN in a Mooney M20J. See Appendix C for a copy of each STC.

All installations must be certified. For more information, see FAA Advisory Circular "Airworthiness Approval of Global Positioning System (GPS) Navigation Equipment for use as a VFR and IFR Supplemental Navigation System", Appendix 1. All new certifications after GARMIN's Mooney installation will be "Follow-On".

## **SECTION 6 CONTINUED AIRWORTHINESS**

Maintenance of the GPS 150XL/GNC 250/GNC 250XL is on condition only. Periodic maintenance of the GPS 150XL/GNC 250/GNC 250XL is not required.

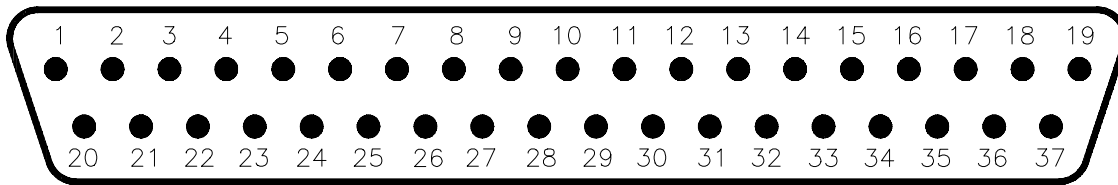

VIEW OF J101 CONNECTOR  
FROM BACK OF RACK

J101		
PIN NO.		
1	----->	D-BAR LEFT +
2	----->	TO +
3	----->	FLAG +
4	----->	FLAG -, D-BAR RIGHT +, FROM +
5	-----	RESERVED
6	-----	RESERVED
7	----->	OBI CLOCK
8	----->	OBI DATA
9	-----	RESERVED
10	----->	NAV SUPER FLAG
11	-----	RESERVED
12	----->	ARRIVAL ANNUN
13	-----	RESERVED
14	-----	RESERVED
15	----->	ARINC 429 OUT B
16	----->	ARINC 429 OUT A
17	<-----	RS232 IN 1
18	-----	RESERVED
19	----->	RS232 OUT 2
20	----->	MESSAGE ANNUN
21	<-----	AIRCRAFT POWER (NOT REQ'D FOR GPS150XL)
22	<-----	GROUND (NOT REQ'D FOR GPS 150XL)
23	----->	OBI SYNC
24	----->	RS232 OUT 1
25	<-----	AIRCRAFT POWER
26	<-----	GROUND
27	-----	RESERVED
28	-----	RESERVED
29	----->	CHARGE ENABLE
30	<-----	BATTERY + (POSITIVE)
31	-----	RESERVED
32	-----	RESERVED
33	-----	RESERVED
34	<-----	BATTERY - (NEGATIVE)
35	-----	RESERVED
36	-----	RESERVED
37	-----	RESERVED

<-- INPUT    OUTPUT-->

FIGURE 1-1 PINOUT DEFINITION, 37 PIN DSUB



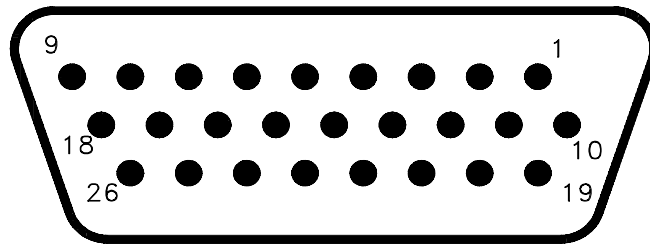

VIEW OF J102 CONNECTOR  
FROM BACK OF RACK

J102  
PIN NO.

1	-----	RESERVED
2	<-----	MIC AUDIO HI
3	<-----	MIC AUDIO LO
4	<-----	MIC KEY
5	----->	COMM AUDIO HI
6	----->	COMM AUDIO LO
7	-----	RESERVED
8	<-----	MIC INTERCOMM
9	-----	RESERVED
10	<-----	REMOTE TRANSFER
11	-----	RESERVED
12	<-----	TRANSMIT INTERLOCK
13	-----	RESERVED
14	<-----	ALTITUDE D4
15	<-----	ALTITUDE A1
16	<-----	ALTITUDE A2
17	<-----	ALTITUDE A4
18	<-----	ALTITUDE B1
19	<-----	ALTITUDE B2
20	<-----	ALTITUDE B4
21	<-----	ALTITUDE C1
22	<-----	ALTITUDE C2
23	<-----	ALTITUDE C4
24	<-----	ALTITUDE COMMON
25	<-----	GROUND
26	<-----	REMOTE ENTER

<--- INPUT    OUTPUT--->

FIGURE 1-2 PINOUT DEFINITION, 26 PIN HD-DSUB  
(GNC 250/GNC 250XL ONLY)

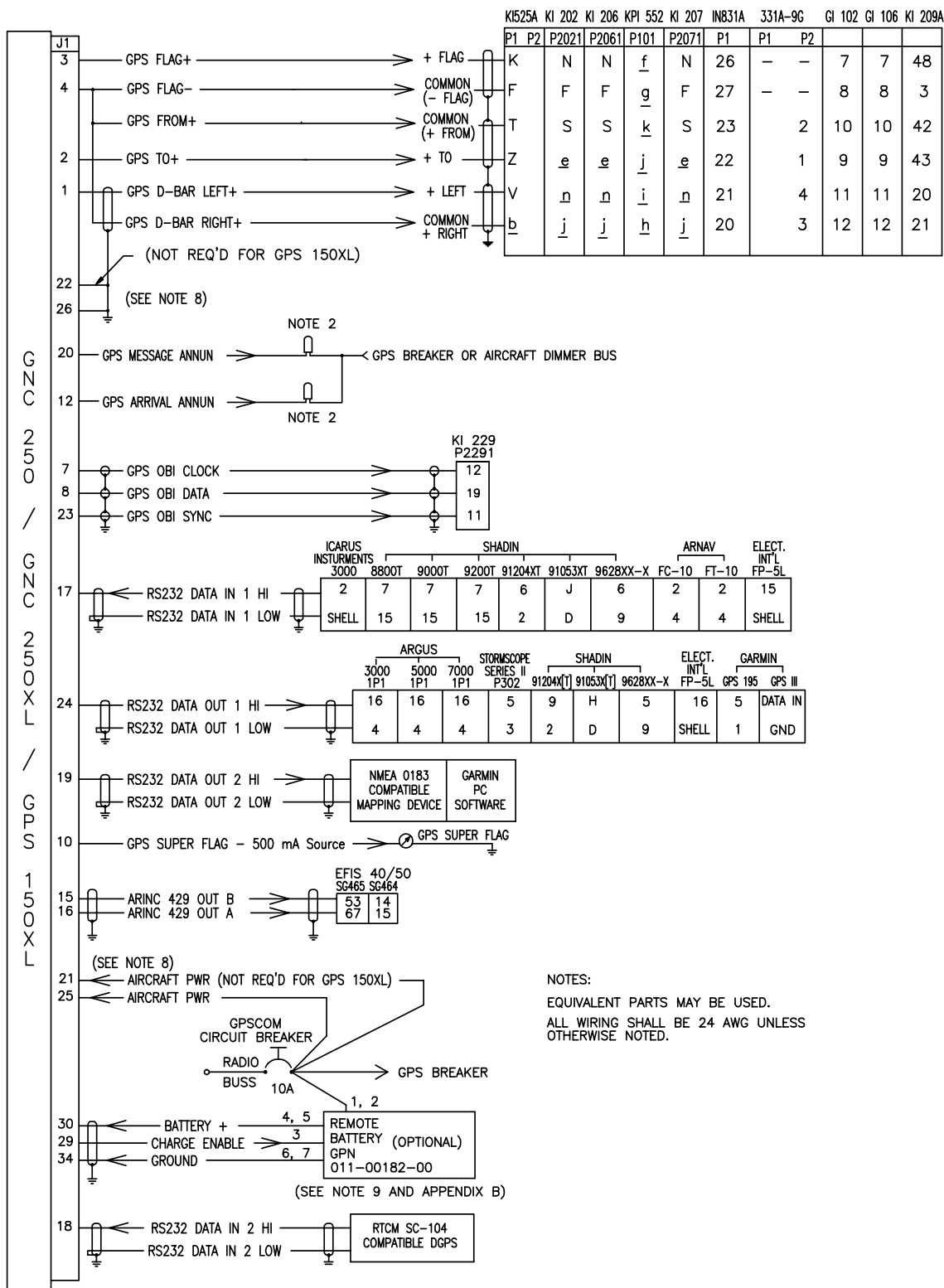

FIGURE 1-3A INTERCONNECT SCHEMATIC

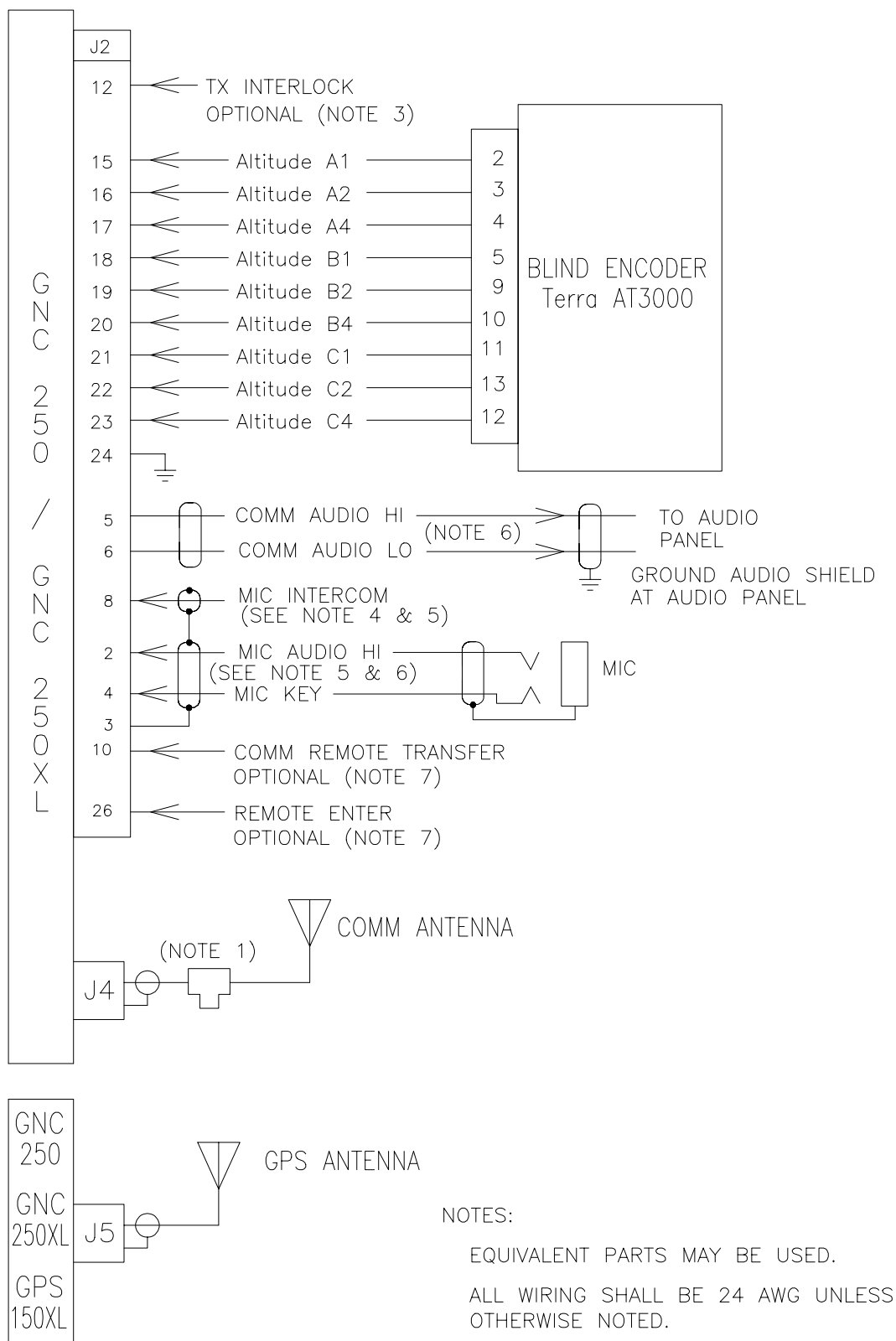
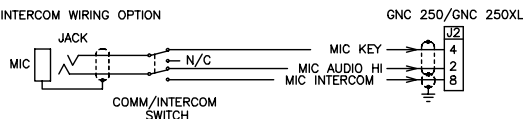

FIGURE 1-3B INTERCONNECT SCHEMATIC

NOTES:

- 1) A 1.575 GHZ NOTCH FILTER (GARMIN p/n 330-00067-00) SHOULD BE INSTALLED IN THE COMM ANTENNA COAX AS CLOSE TO THE COMM TRANSMITTER AS POSSIBLE.
- 2) ANNUNCIATOR OUTPUTS SINK 500 mA MAX.
- 3) CONNECT TX INTERLOCK (J2-12) TO THE SECOND COMM'S MIC KEY TO MINIMIZE SQUELCH BREAKING ON THE GNC 250/GNC 250XL WHEN THE SECOND COMM IS KEYED.

4) INTERCOM WIRING OPTION



5) MIC WIRING

CONNECTING 2 MIC'S TO THE MIC AUDIO HI/LO OR MIC INTERCOM AT THE SAME TIME MAY LOAD DOWN THE MIC BIAS AND RESULT IN WEAK OR DISTORTED AUDIO. MIC ISOLATION RELAYS ARE RECOMMENDED SO THAT ONLY ONE MIC IS ACTIVE AT A TIME.

6) EMERGENCY COMM USE

ALLOW FOR DIRECT CONNECTION OF HEADPHONES AND MICROPHONE TO THE GNC 250/GNC 250XL TO TAKE FULL ADVANTAGE OF THE REMOTE BATTERY PACK (GPN 011-00182-00). IN THE EVENT OF POWER LOSS OR FAILURE OF AN AUDIO PANEL, THIS WILL ALLOW THE USE OF THE GNC 250/GNC 250XL. DIRECT CONNECTION MAY ALREADY BE IMPLEMENTED, OR ACCOMPLISHED VIA AN EMERGENCY POSITION ON AN AUDIO PANEL, OR EMERGENCY JACKS MAY BE INSTALLED AS SHOWN BELOW.

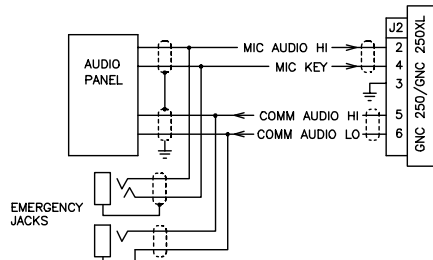

7) COMM REMOTE TRANSFER AND ENTER (OPTIONAL)

IF REMOTE TRANSFER IS NOT DESIRED, NO CONNECTION IS REQUIRED TO J2-10  
IF REMOTE ENTER IS NOT DESIRED, NO CONNECTION IS REQUIRED TO J2-26  
USE SPST MOMENTARY SWITCH FOR EACH FUNCTION.

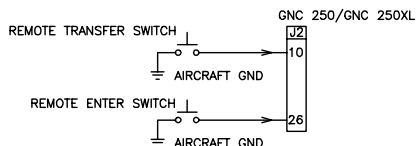

8) AIRCRAFT POWER AND GROUND CONNECTIONS

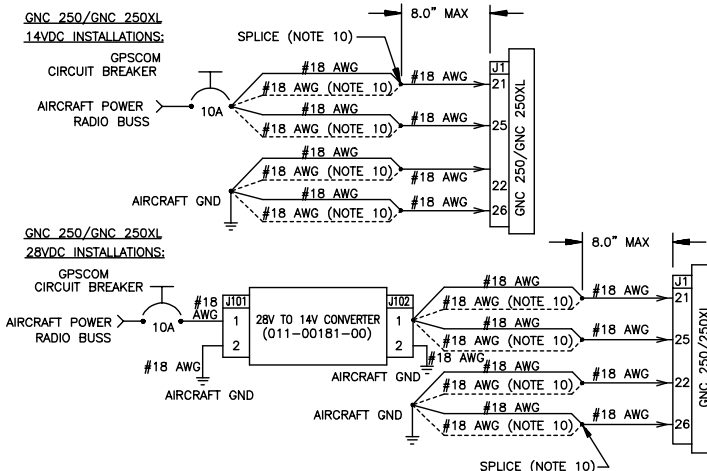

GPS 150XL INSTALLATIONS

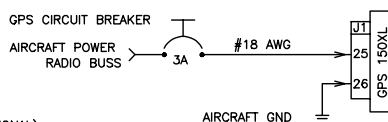

9) REMOTE BATTERY PACK (OPTIONAL)

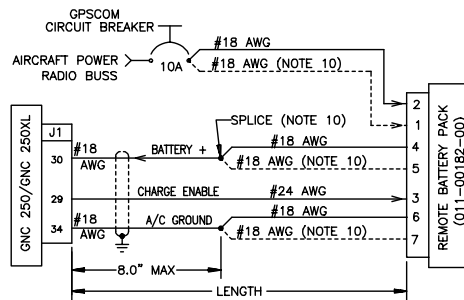

10) WIRE SIZE AND POWER LINE SPLICING

MAXIMUM ALLOWABLE WIRE GAUGE INTO GNC 250/GNC 250XL/GPS 150XL J1 AND 011-00182-00 PINS IS #22 AWG. FOR 18 AWG WIRE/TERMINATION AT GNC 250/GNC 250XL, USE SPECIAL 18 AWG TERMINATION SOCKET CONTACT (336-00023-00) SUPPLIED WITH CONNECTOR KIT. FOR REMOTE BATTERY PACK, USE SPECIAL 18 AWG TERMINATION PIN CONTACT (336-00025-00) SUPPLIED WITH REMOTE BATTERY. PROTECT EXPOSED CONDUCTOR ON SPECIAL LARGE TERMINATION CONTACTS WITH 3/8" [1 cm] LENGTH OF SHRINK TUBING (312-00005-05), SUPPLIED WITH CONNECTORS.

GNC 250/GNC 250XL:

FOR 6 FEET AND LESS, USE 1 #18 AWG FOR EACH CONNECTION (NO SPLICE). FOR 6-12 FEET, USE 2 #18 AWG FOR EACH CONNECTION. USE GPN 330-00165-01 SOLDERLESS CONNECTOR (LARGE), AS CLOSE TO CONNECTOR AS POSSIBLE (8.0" MAX). USE JST CRIMP TOOL YS1614 OR EQUIVALENT.

GPS 150XL

FOR 0-12 FEET, USE (1) #18 AWG FOR EACH CONNECTION (NO SPLICE).

11) SIGNAL LINE SPLICING

USE GPN 330-00165-00 SOLDERLESS CONNECTOR (SMALL) TO SPLICE 3 TO 8 #24 AWG WIRES. USE JST CRIMP TOOL YS2216 OR EQUIVALENT.

FIGURE 1-4 INTERCONNECT SCHEMATIC NOTES

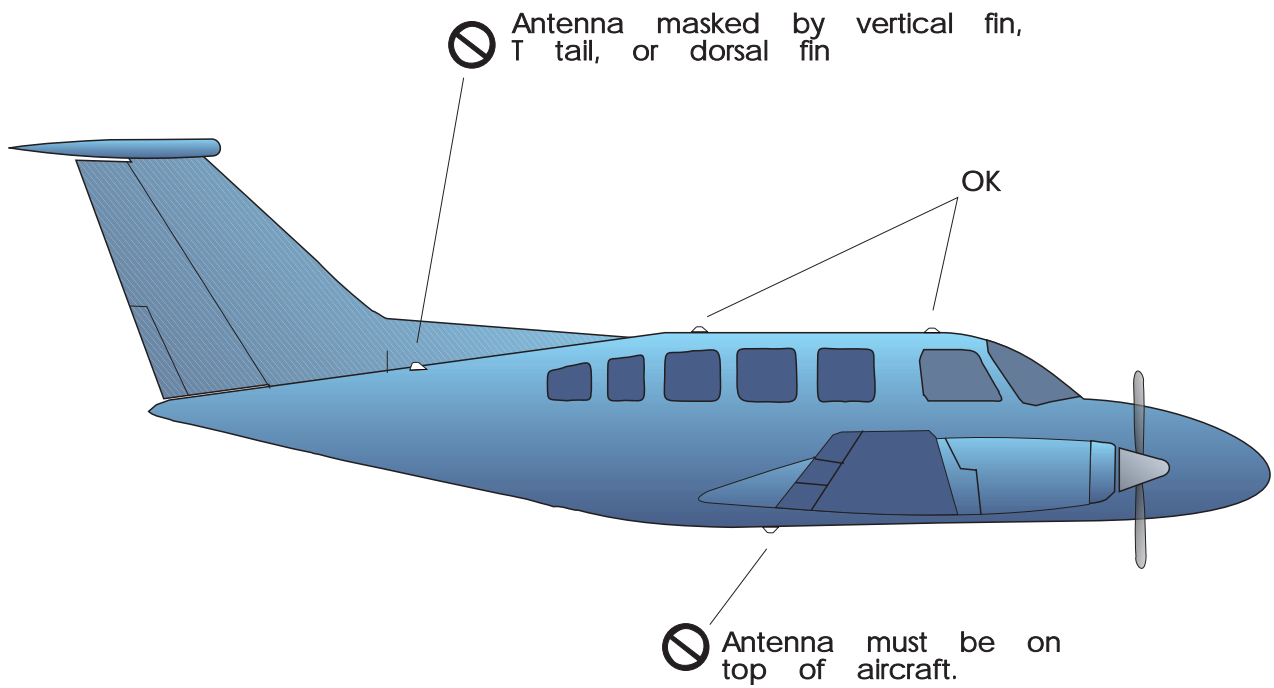

FIG 2-1  
GPS ANTENNA INSTALLATION CONSIDERATIONS

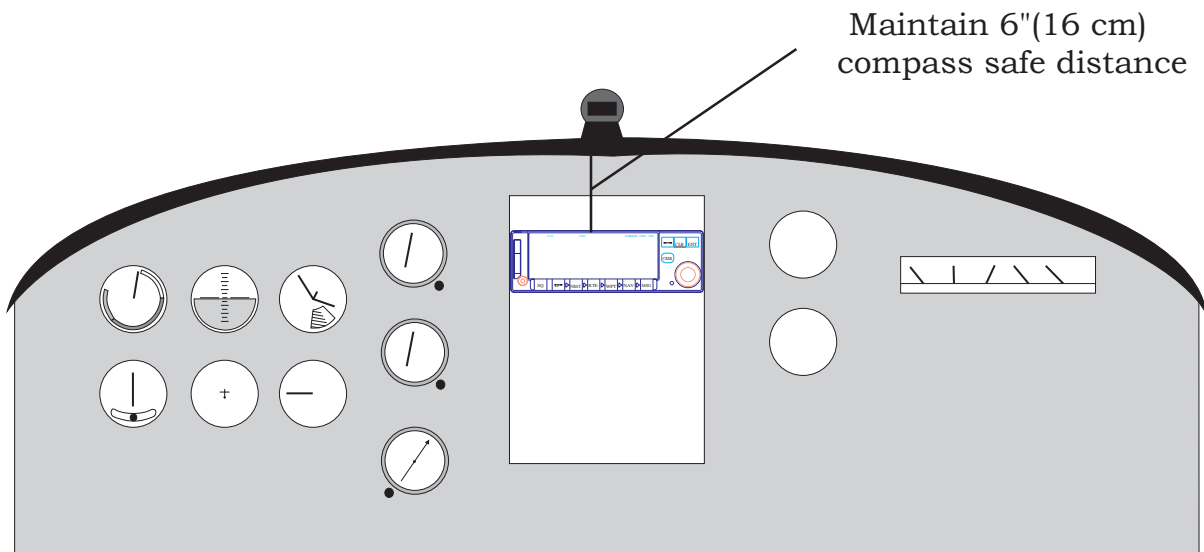
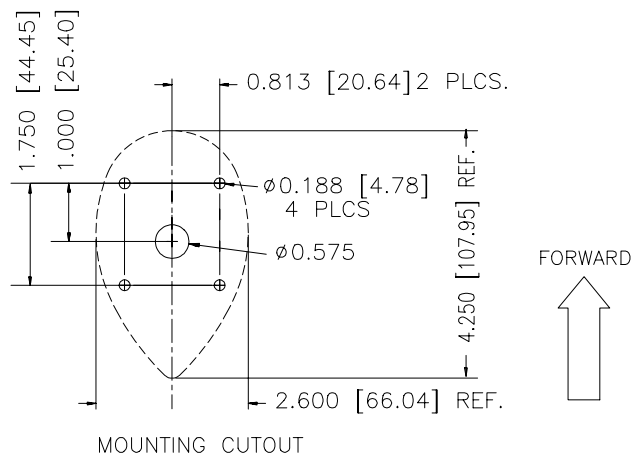
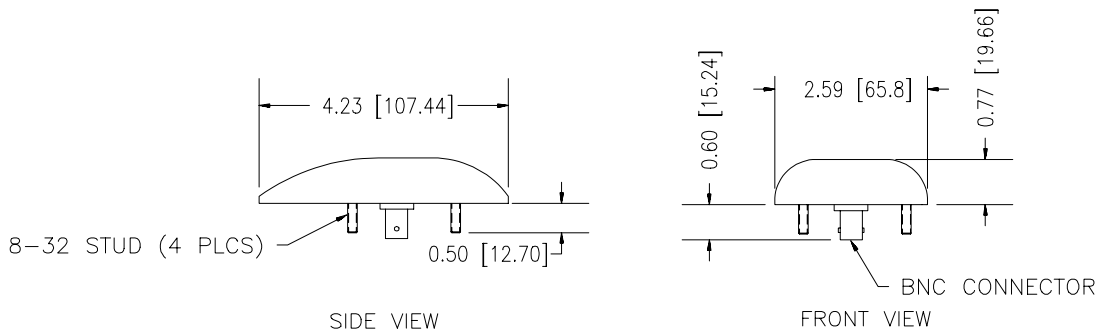
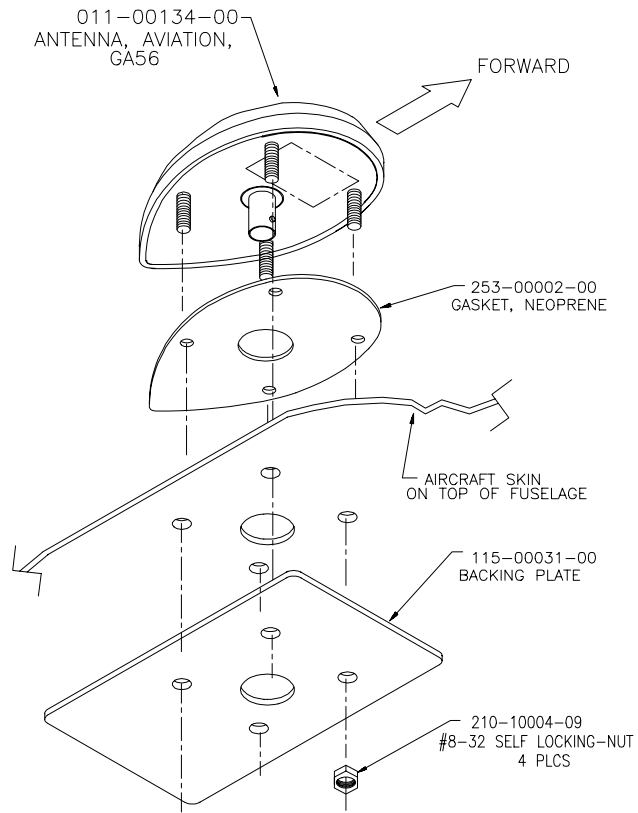
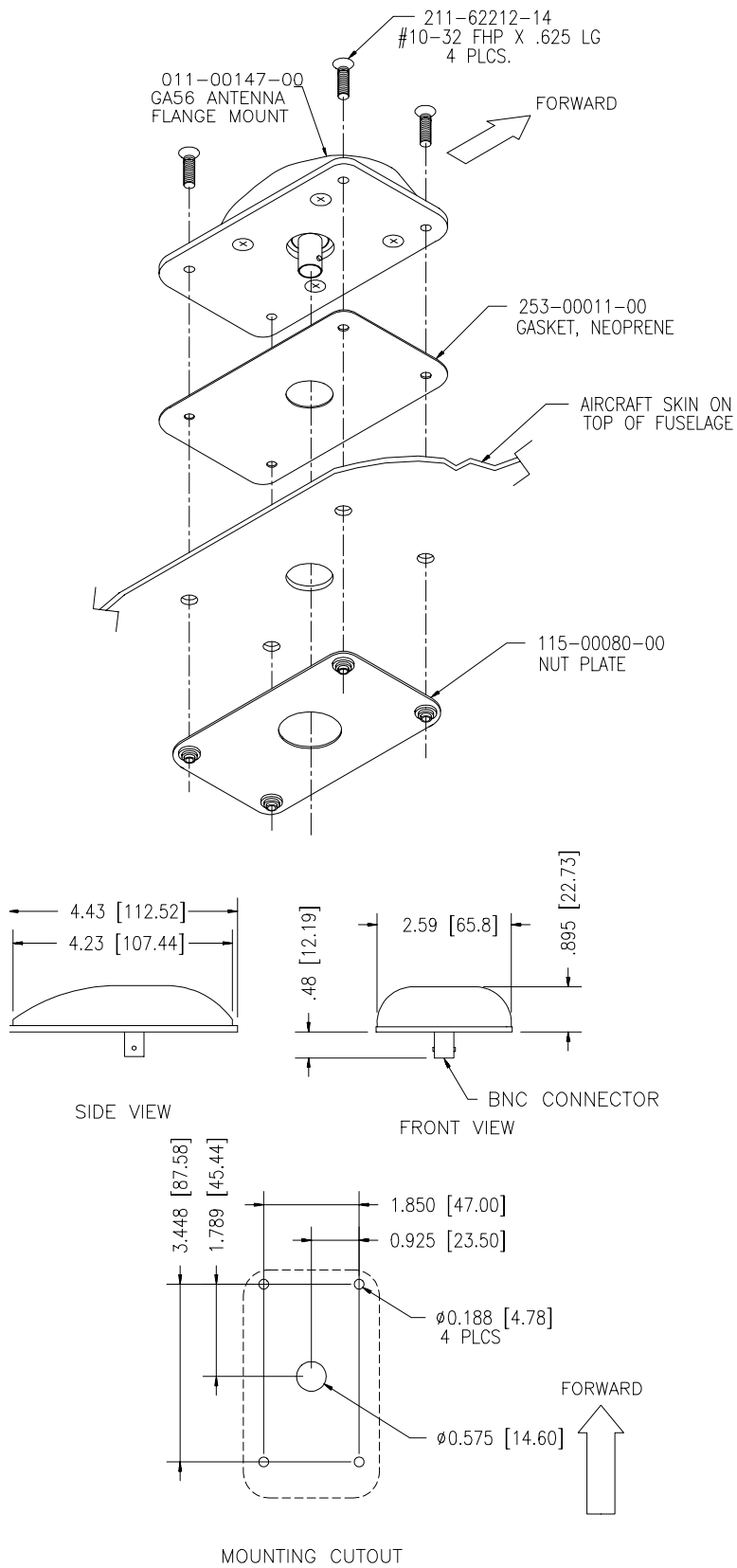

FIG 2-2  
UNIT INSTALLATION CONSIDERATIONS



**FIG 3-1**  
**STUD MOUNT GA 56 ANTENNA INSTALLATION**



**FIGURE 3-2**  
**FLANGE MOUNT GA 56 ANTENNA INSTALLATION**

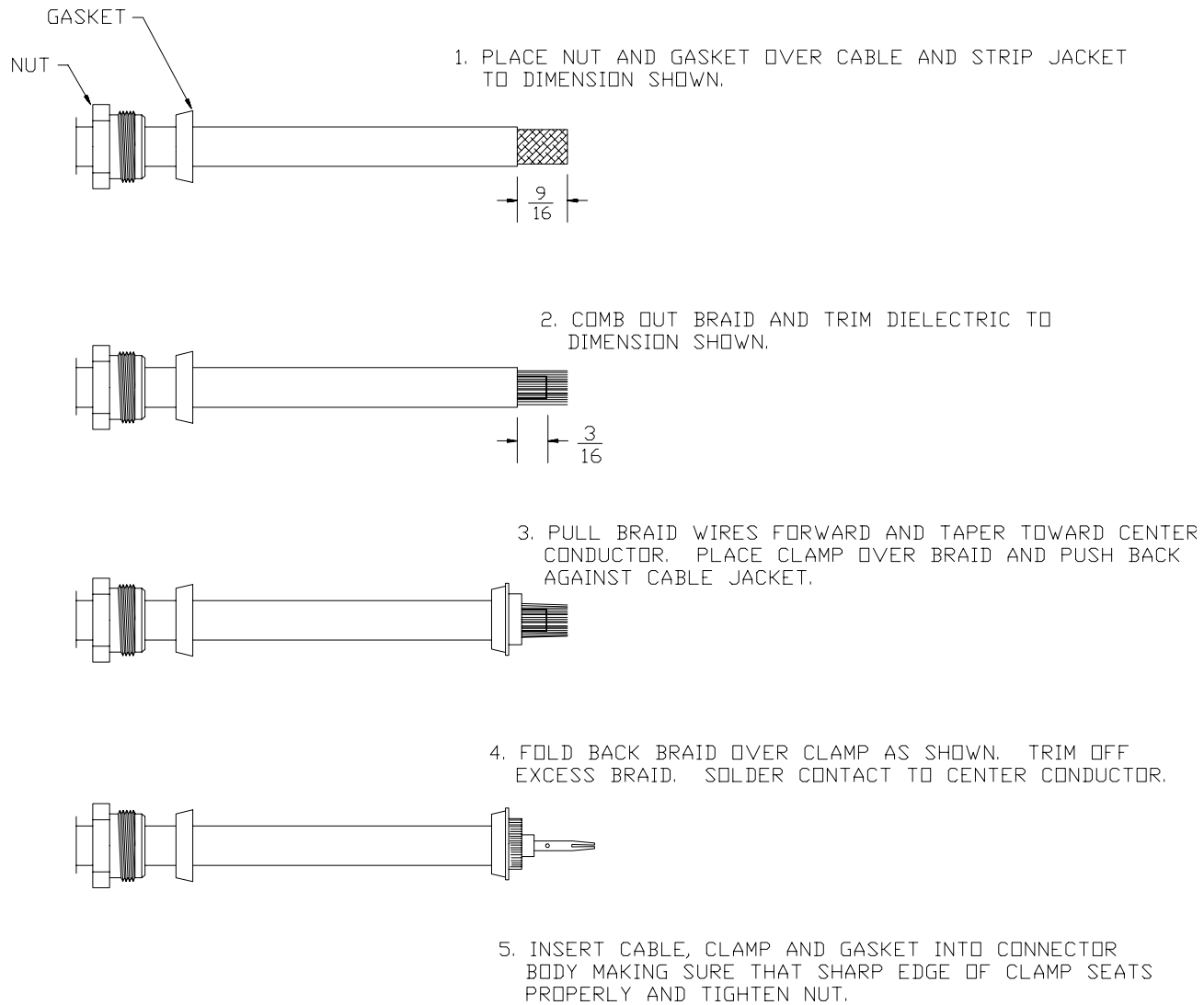
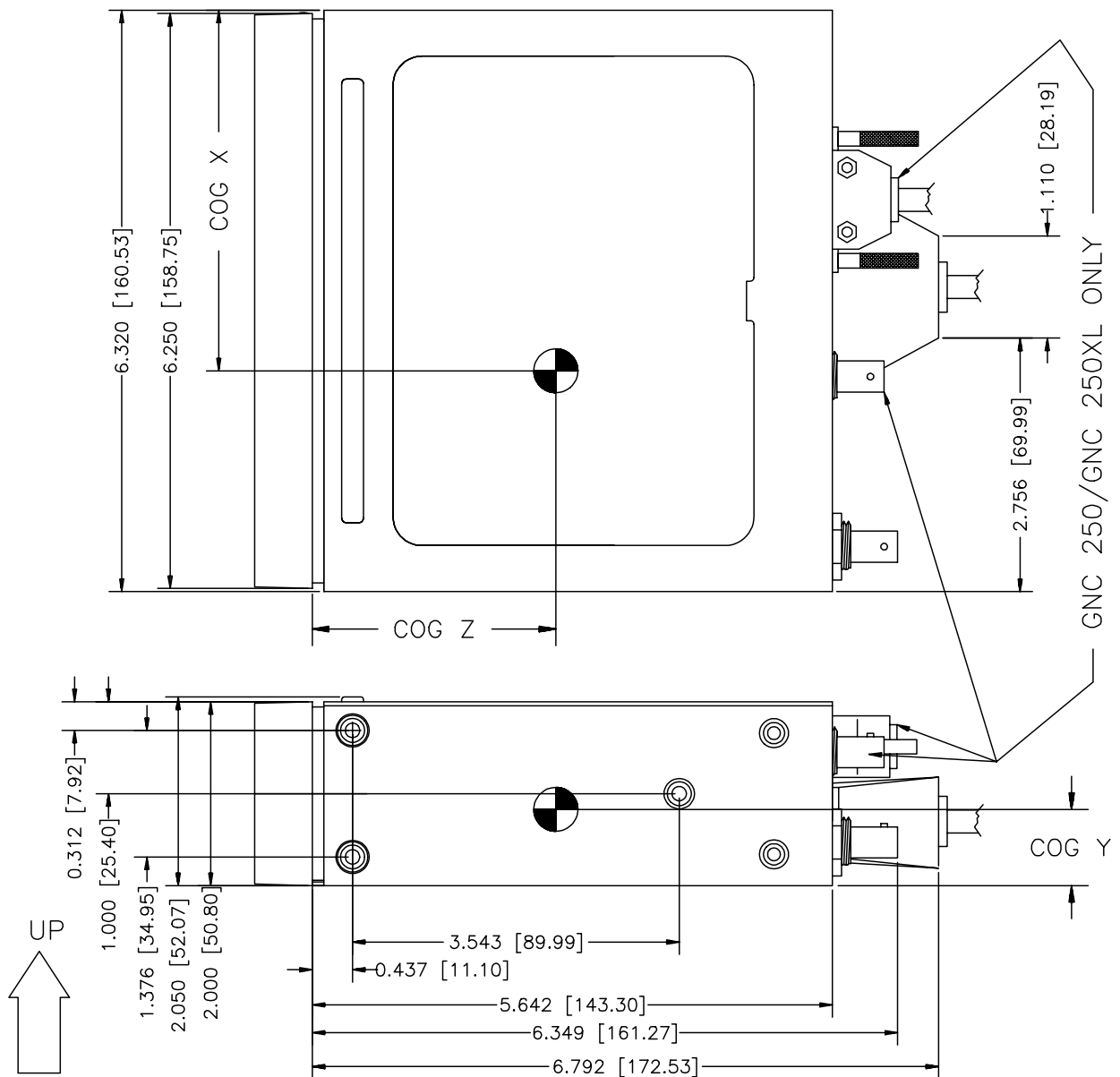

FIGURE 3-3 COAX CABLE INSTALLATION





	COG X	COG Y	COG Z	Unit Weight w/o Rack
GNC 250	3.56"	1.00"	2.64"	2.4 LBS
GNC 250XL	3.40"	0.93"	2.34"	2.6 LBS
GPS 150XL	3.45"	0.85"	2.19"	1.7 LBS

FIGURE 3-4 AVIATION RACK DIMENSIONS

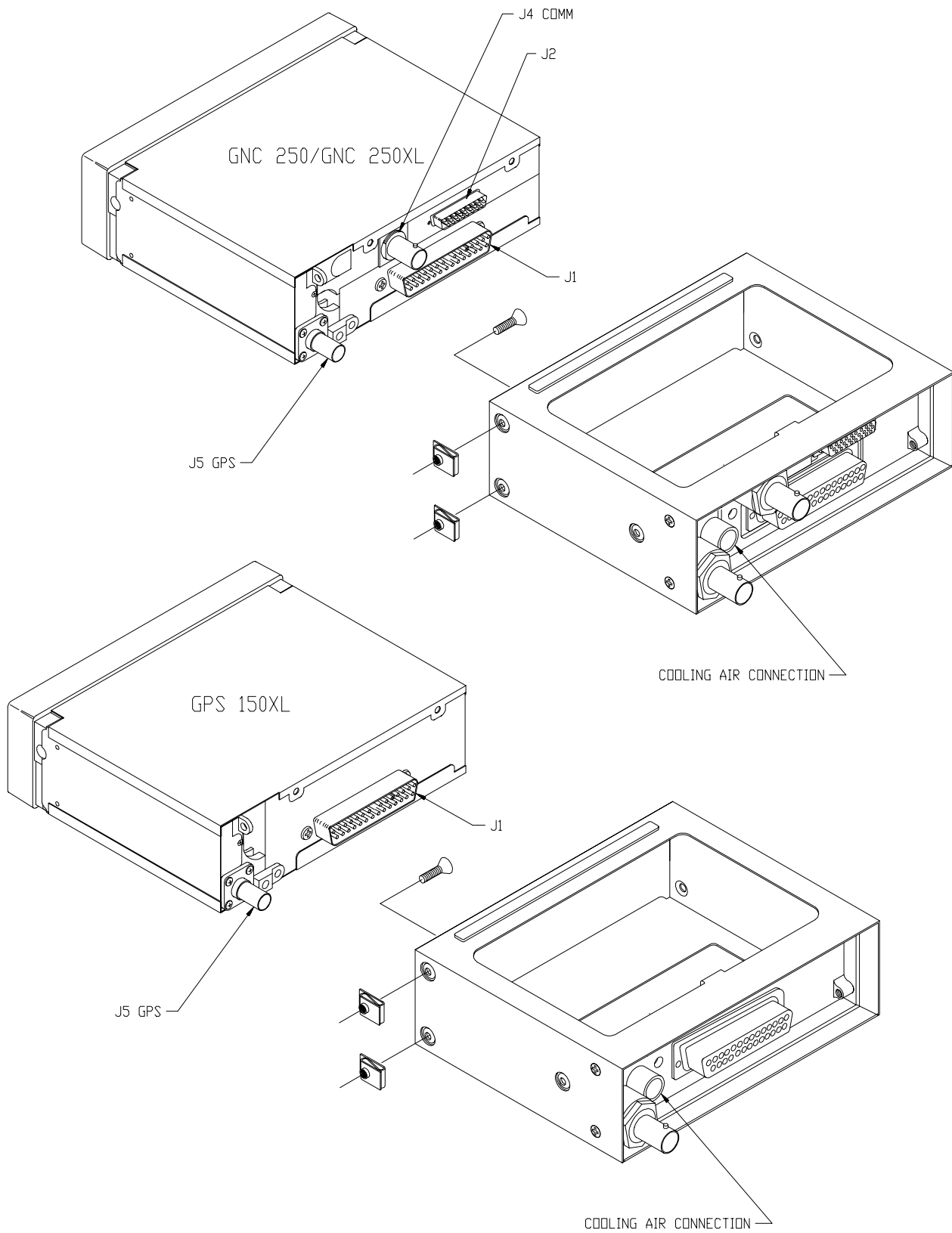

FIGURE 3-5 AVIATION RACK INSTALLATION

# APPENDIX A CERTIFICATION DOCUMENTS

## ENVIRONMENTAL QUALIFICATION FORM

NOMENCLATURE: GNC 250, GPS AIRBORNE RNAV / COMM SYSTEM  
 GNC 250XL, GPS AIRBORNE RNAV / COMM SYSTEM  
 TYPE/MODEL/PART NO: 011-00082-00 (GNC 250)  
 011-00295-00 (GNC 250XL)  
 011-00345-00 (GPS 150XL)

GPS: ADVISORY CIRCULAR 20-138 (VFR)  
 COMM TRANSMITTER TSO: (GNC 250/GNC 250XL ONLY) C37d CLASS 4  
 VHF COMM RECEIVER TSO: GNC 250/GNC 250XL ONLY) C38d CLASS C

MANUFACTURER'S SPECIFICATION AND/OR OTHER APPLICABLE SPECIFICATION: 004-00014-00

MANUFACTURER: GARMIN INTERNATIONAL, INC.

ADDRESS: 1200 E. 151ST STREET, OLATHE, KANSAS 66062-3426

Conditions 1/	Section	Description of Conducted Tests
Temperature and Altitude	4.0	Equipment tested to Categories A1 & D1 except as noted
Low Temperature	4.5.1	
High Temperature	4.5.2. & 4.5.3	
In-Flight Loss of Cooling	4.5.4	Cooling air not required
Altitude	4.6.1	
Decompression	4.6.2	
Overpressure	4.6.3	Not tested
Temperature Variation	5.0	Equipment tested to Category C
Humidity	6.0	Equipment tested to Category A
Shock	7.0	Equipment tested per DO-160C, Par. 7.2.1
Operational	7.2	
Crash Safety	7.3	
Vibration	8.0	Equipment tested without shock mounts to Categories B, M and N (Table 8-1)
Explosion	9.0	Equipment identified as Category X, no test required
Waterproofness	10.0	Equipment identified as Category X, no test required
Fluids Susceptibility	11.0	Equipment identified as Category X, no test required

1/ The information listed below provides examples only. It is not intended to be a comprehensive listing of all test conditions.

Conditions 1/	Section	Description of Conducted Tests
Sand and Dust	12.0	Equipment identified as Category X, no test required
Fungus	13.0	Equipment identified as Category X, no test required
Salt Spray	14.0	Equipment identified as Category X, no test required
Magnetic Effect	15.0	Equipment tested is Class Z
Power Input	16.0	Equipment tested to Category B
Voltage Spike	17.0	Equipment tested to Category A
Audio Frequency Susceptibility	18.0	Equipment tested to Category B
Induced Signal Susceptibility	19.0	Equipment tested to Category A
Radio Frequency Susceptibility	20.0	Equipment tested to Category T
Radio Frequency Emission	21.0	Equipment tested to Category Z
Lightning Induce Transient Susceptibility	22.0	Equipment identified as Category XXXX, no test required
Lightning Direct Effects	23.0	Equipment identified as Category X, no test required
Icing	24.0	Equipment identified as Category X, no test required
Other Tests		
Remarks: Software: DO-178C, Level C (Major)		

## ENVIRONMENTAL QUALIFICATION FORM

NOMENCLATURE: GA 56, GPS AVIATION ANTENNA

TYPE/MODEL/PART NO.: 011-00134-00/01/02

TSO NUMBER: C129  
CLASS A(1)

MANUFACTURER'S SPECIFICATION AND/OR OTHER APPLICABLE SPECIFICATION: 004-00015-00

MANUFACTURER: GARMIN INTERNATIONAL, INC.

ADDRESS: 1200 E. 151ST STREET, OLATHE, KANSAS 66062-3426

Conditions 1/	Section	Description of Conducted Tests
Temperature and Altitude	4.0	Equipment tested to Category F2
Low Temperature	4.5.1	
High Temperature	4.5.2. & 4.5.3	
In-Flight Loss of Cooling	4.5.4	Cooling air not required
Altitude	4.6.1	
Decompression	4.6.2	Not tested
Overpressure	4.6.3	Not tested
Temperature Variation	5.0	Equipment tested to Category A
Humidity	6.0	Equipment tested to Category C
Shock	7.0	Equipment tested per DO-160C, Par. 7.2.1
Operational	7.2	
Crash Safety	7.3	Not applicable
Vibration	8.0	Equipment tested without shock mounts to Categories C, L, M and Y (Table 8-1)
Explosion	9.0	Equipment identified as Category X, no test required
Waterproofness	10.0	Equipment tested to Category S
Fluids Susceptibility	11.0	Equipment tested to Category F with Ethylene Glycol De-Icing Fluid

1/ The information listed below provides examples only. It is not intended to be a comprehensive listing of all test conditions.

Conditions 1/	Section	Description of Conducted Tests
Sand and Dust	12.0	Equipment identified as Category X, no test required
Fungus	13.0	Equipment identified as Category X, no test required
Salt Spray	14.0	Equipment identified as Category X, no test required
Magnetic Effect	15.0	Equipment identified as Category X, no test required
Power Input	16.0	Equipment identified as Category X, no test required
Voltage Spike	17.0	Equipment identified as Category X, no test required
Audio Frequency Susceptibility	18.0	Equipment identified as Category X, no test required
Induced Signal Susceptibility	19.0	Equipment identified as Category A
Radio Frequency Susceptibility	20.0	Equipment identified as Category T
Radio Frequency Emission	21.0	Equipment identified as Category Z
Lightning Induce Transient Susceptibility	22.0	Equipment identified as Category X, no test required
Lightning Direct Effects	23.0	Equipment tested to Category 2A
Icing	24.0	Equipment tested to Category C
Other Tests		
Remarks:		

## APPENDIX B CONNECTOR CHANGES

### STAMPED CONTACT CONNECTOR USAGE

Garmin panel mount GPS radios have previously been shipped with stamped crimp type contacts. All products are now being shipped with machined mil-spec contacts with color-coded barrels. The following figures can be used to identify which type contact you have:

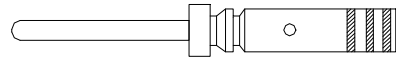

NEW MACHINED CONTACT

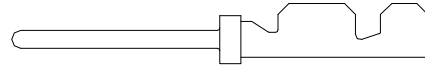

OLD STAMPED CONTACT

Some contacts are pins as shown, while others are the socket type. The type used will vary with the installation. When working with the stamped crimp type contacts, the following tools should be used:

Tools	37 and 9 position connectors		26 position connector	
supplier	Crimp Tool	Extraction Tool	Crimp Tool	Extraction Tool
Amp	58448-2	91067-22	90430-1	91285-1
ITT Cannon	995-2000-000	980-0008-124	995-2000-022	980-00004-804
Cinch	HTD-544	CIET-20-HDB	HTD-544	HTD-520

Part numbers shown are not maintained by Garmin and consequently are subject to change without notice.

When stamped contacts are used special considerations must be made for aircraft power and remote battery (optional) connections, as shown in the following diagram:

#### 1) AIRCRAFT POWER AND GROUND CONNECTIONS

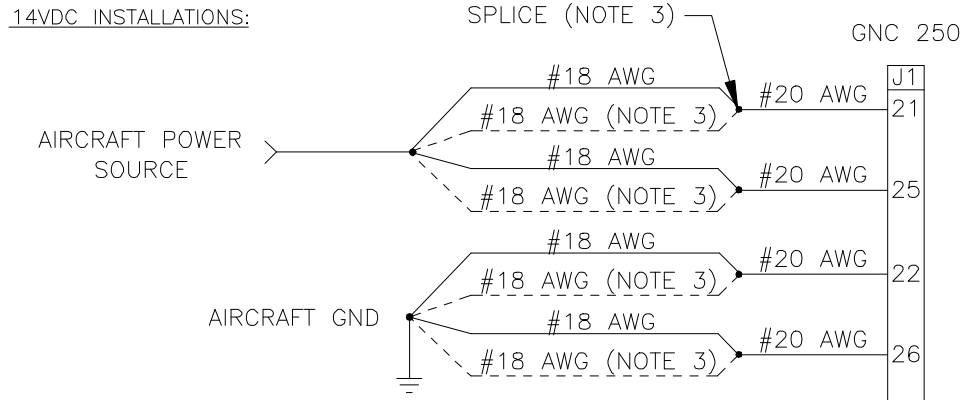

2) REMOTE BATTERY PACK (OPTIONAL)

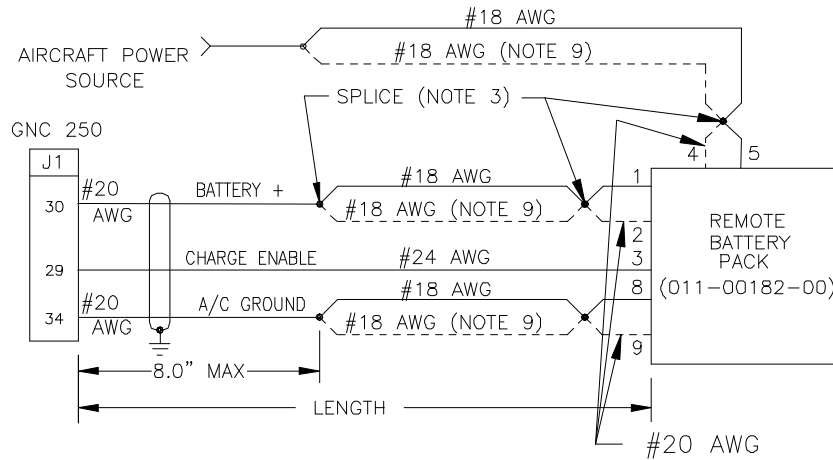

9) WIRE SIZE AND POWER LINE SPLICING

FOR 6 FEET AND LESS, USE 1 #18 AWG FOR EACH CONNECTION. FOR 6-12 FEET, USE 2 #18 AWG FOR EACH CONNECTION. MAXIMUM ALLOWABLE WIRE GAUGE INTO GNC 250 J1 AND 011-00182-00 PINS IS #20 AWG. USE GPN 330-00165-01 SOLDERLESS CONNECTOR (LARGE) AS CLOSE TO CONNECTOR AS POSSIBLE (8.0" MAX). USE JST CRIMP TOOL YS1614 OR EQUIVALENT.

## REMOTE BATTERY PIN ASSIGNMENTS

A change was made to the remote battery connectors starting with serial numbers 33050055. Units with lower serial numbers have pin contacts on the battery pack. Units 33050055 and up use socket contacts on the battery and the pin number assignments are different, however the individual contact locations are unchanged. The following table shows the pin assignments for the two different types of connectors:

Serial Number	below 33050055	33050055 and up
remote batt.	Pins	sockets
mating plug	sockets	pins
function	contact number	contact number
battery +	1	5
battery +	2	4
charge enable	3	3
aircraft power	4	2
aircraft power	5	1
no connection	6	9
no connection	7	8
ground	8	7
ground	9	6



## **APPENDIX C STC PERMISSION**

### **GNC 250:**

Consistent with N8110.69 or Order 8110.4, Aviation Authority approved installers are hereby granted permission to use STC# SA00336WI data to modify aircraft.

### **GNC 250XL:**

Consistent with N8110.69 or Order 8110.4, Aviation Authority approved installers are hereby granted permission to use STC# SA00502WI data to modify aircraft.

### **GNC 150XL:**

Consistent with N8110.69 or Order 8110.4, Aviation Authority approved installers are hereby granted permission to use STC# SA00503WI data to modify aircraft.

United States Of America  
Department of Transportation - Federal Aviation Administration  
**Supplemental Type Certificate**

*Number* SA00336WI

*This Certificate issued to* Garmin International  
9875 Widmer Road  
Lenexa, KS 66215

*certifies that the change in the type design for the following product with the limitations and conditions therefor as specified hereon meets the airworthiness requirements of Part 3 of the Civil Air Regulations.*

*Original Product - Type Certificate Number:* 2A3  
*Make:* Mooney  
*Model:* M20J

*Description of Type Design Change:* Installation of GARMIN GNC 250 VHF COMM/GPS Receiver in accordance with (1) GARMIN Master Drawing List, GNC 250 Installation of Mooney Model M20J, Revision B, dated June 30, 1995, and (2) FAA Approved Airplane Flight Manual Supplement (AFMS) for Mooney M20J with GARMIN GNC 250 VHF Communication Transceiver/GPS Receiver dated June 30, 1995, or later FAA Approved Revisions to (1) or (2).

*Limitations and Conditions:* Compatibility of this design change with previously approved modifications must be determined by the installer.

*This certificate and the supporting data which is the basis for approval shall remain in effect until surrendered, suspended, revoked or a termination date is otherwise established by the Administrator of the Federal Aviation Administration.*

*Date of application:* August 28, 1994

*Date reissued:*

*Date of issuance:* June 30, 1995

*Date amended:*



*By direction of the Administrator*  
*James M. Peterson*  
(Signature)  
James M. Peterson  
Associate ACO Mgr., Systems & Propulsion  
Wichita Aircraft Certification Office

(Title)

*Any alteration of this certificate is punishable by a fine of not exceeding \$1,000, or imprisonment not exceeding 3 years, or both.*

FAA Form 8110-2(10-68)

*This certificate may be transferred in accordance with FAR 21.47.*

United States of America  
Department of Transportation -- Federal Aviation Administration  
**Supplemental Type Certificate**

*Number* SA00502WI

*This certificate issued to* Garmin International  
1200 East 151st Street  
Olathe, KS 66062

*certifies that the change in the type design for the following product with the limitations and conditions therefor as specified hereon meets the airworthiness requirements of Part 3 of the Civil Air Regulations.*

*Original Product - Type Certificate Number:* 2A3  
*Make:* Mooney  
*Model:* M20J

*Description of Type Design Change:*

Installation of the GARMIN GNC 250XL VHF Communication Transceiver / GPS Receiver in accordance with (1) Garmin Corporation Master Drawing List, Drawing No. 005-00049-00, Revision E, dated March 7, 1997, and (2) FAA Approved Airplane Flight Manual Supplement for Mooney M20J with GARMIN GNC 250XL VHF Communication Transceiver / GPS Receiver, Revision A, dated February 11, 1997, or later FAA approved revision to (1) or (2).

*Limitations and Conditions:* Compatibility of this design change with previously approved modifications must be determined by the installer

*This certificate and the supporting data which is the basis for approval shall remain in effect until surrendered, suspended, revoked or a termination date is otherwise established by the Administrator of the Federal Aviation Administration.*

*Date of application:* February 21, 1996

*Date reissued:*

*Date of issuance:* April 24, 1997

*Date amended:*



*By direction of the Administrator*

*James M. Peterson*  
(Signature)  
James M. Peterson  
Associate ACO Mgr., Systems & Propulsion  
Wichita Aircraft Certification Office

(Title)

Any alteration of this certificate is punishable by a fine of not exceeding \$1,000, or imprisonment not exceeding 3 years, or both.

FAA FORM 8110-2(10-68) PAGE 1 of 1 PAGES

This certificate may be transferred in accordance with FAR 21.47.

United States of America  
Department of Transportation -- Federal Aviation Administration  
**Supplemental Type Certificate**

*Number* SA00503WI

*This certificate issued to* Garmin International  
1200 E. 151st street  
Olathe, KS 66062

*certifies that the change in the type design for the following product with the limitations and conditions therefor as specified hereon meets the airworthiness requirements of Part 3 of the Civil Air Regulations.*

*Original Product - Type Certificate Number:* 2A3

*Make:* Mooney

*Model:* M20J

*Description of Type Design Change:*

Installation of the GARMIN GPS 150XL Global Positioning System in accordance with (1) Garmin Corporation Master Drawing List, Drawing No. 005-00058-00, Revision D, dated March 7, 1997, and (2) FAA Approved Airplane Flight Manual Supplement for Mooney M20J with GARMIN GPS 150XL Global Positioning System, Revision A, dated February 11, 1997, or later FAA approved revision to (1) or (2).

*Limitations and Conditions:* Compatibility of this design change with previously approved modifications must be determined by the installer.

*This certificate and the supporting data which is the basis for approval shall remain in effect until surrendered, suspended, revoked or a termination date is otherwise established by the Administrator of the Federal Aviation Administration.*

*Date of application:* November 08, 1996

*Date reissued:*

*Date of issuance:* April 24, 1997

*Date amended:*



*By direction of the Administrator*

*James M. Peterson*  
(Signature)

James M. Peterson  
Associate ACO Mgr., Systems & Propulsion  
Wichita Aircraft Certification Office

(Title)

Any alteration of this certificate is punishable by a fine of not exceeding \$1,000, or imprisonment not exceeding 3 years, or both.

FAA FORM 8110-2(10-68) PAGE 1 of 1 PAGES

This certificate may be transferred in accordance with FAR 21.47.